

Be the leader in your town with the S 47 SX from Schwing America. With a horizontal reach of 141 feet and a vertical reach of 154 feet, the S 47 SX was designed with operators and owners in mind. The S 47 SX features Schwing's expanded Super-X stabilizers, the industry's first telescoping curved front outriggers. These outriggers telescope into the chassis for compact storage and overall lower structural height. This allows for an optimal

boom slewing gear design and accommodates extra-long stroke pumpkits. On the job, the SX outriggers telescope out and around obstructions that block conventional swing-out stabilizers. Controls on both sides of the chassis are a convenience feature.

The S 47 SX is the latest in a long history of Schwing manufacturing that provides quality equipment without planned obsolescence.

Many Schwing pumps introduced twenty years ago are still on the job.

Purchase of a Schwing unit means a well-designed, reliable piece of equipment that enjoys the highest resale in the industry. Plan on profitable pumping with the S 47 SX designed with operators and owners in mind because - we engineer success!

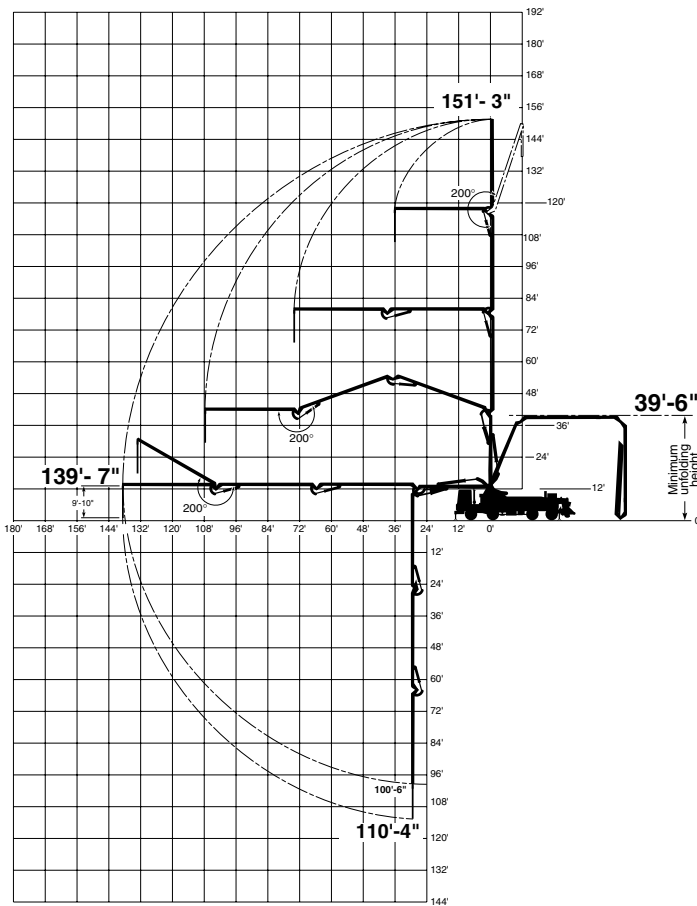
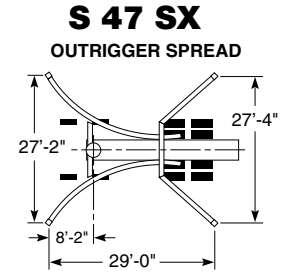

Boom Specifications

U.S.

Metric

Pipeline Diameter	*5"	*112 mm	
Vertical Reach	154.5'	47 m	
Reach from Slewing Axis	141.5'	43.1 m	
Net Horizontal Reach	129.5'	39.5 m	
Unfolding Height	39.6'	12 m	
Section Length	First Section	27.4'	8.35 m
	Second Section	38'	11.6 m
	Third Section	38'	11.6 m
	Fourth Section	38.2'	11.65 m
Slewing Range	380°	380°	
4.4" End hose length* (coupled one end only)	9'	2.74 m	

Specifications are subject to change without prior notice. *Tip section pipeline diameter is 4.4" or 112 mm.

Pump Kits on S 47 SX

	2023-4	2023-5	2525-5	2525H-6
Theor. Concrete Output (cu./yds/hr)	170	209	173	213
Max. Pressure on Concrete (psi)	1007	1007	1169	1169
Max. Strokes/Min.	26	32	18	22
Pump Cylinder Diameter (in.)	9	9	10	10
Pump Cylinder Stroke Length (in.)	79	79	98	98
Differential Cylinder Size (in.)	5.1	5.1	4.7	4.7
Max. Aggregate Size (in.)	2.5	2.5	2.5	2.5
Max. Hydraulic System Pressure (psi)	5075	5075	5075	5075

Specifications are subject to change without prior notice



5900 Centerville Road
 St. Paul, MN 55127
 Tel 1-888-SCHWING
 Fax 651-429-3464
 www.schwing.com

Represented by